

These Standards shall supersede all previous Design and Development Standards whether recorded among the Land Records of Collier County or not.

VILLA FLORESTA DESIGN AND DEVELOPMENT STANDARDS

Villa Floresta Homeowners Association, Inc. - 98 Wyndemere Way, Naples, Florida 34105

Approved: Villa Floresta Architectural Review Committee (ARC) **Date:** November 8, 2023

Villa Floresta Board of Directors **Date:** November 14, 2023

Wyndemere Homeowners Association ARC **Date:** November 29, 2023

Adopted by the Villa Floresta Board of Directors **Date: December 18, 2023**

The "Declaration of Covenants, Restrictions and Easements for Villa Floresta" ("Declaration"), Section 10, provides for "Architectural and Aesthetic Control." Under that section, an Architectural Review Committee (ARC), appointed by the Board of Directors, is empowered to publish or modify design and development standards ("Standards").

The purpose of this document is to provide the "Standards" for Villa Floresta as required in the "Declaration", Section 10, which states: "No construction, which term shall include within its definition, but not limited to, staking, clearing, excavation, grading and other site work; no exterior alteration or modification of existing improvements; or removal of trees or shrubs shall take place anywhere on the Community until the approval of the ARC has been obtained." In addition, the Wyndemere Homeowners Association ("Master Association") Declaration, Article VI, "Restrictions on Occupancy and Use of Land" requires approval by the Master Association ARC. The appropriate ARC Change Form to initiate all projects is available at the Wyndemere Homeowners Association office.

The Criteria for any item not contained in these Villa Floresta Design and Development Standards (Standards), shall be whatever already physically exists within the Community for such an item unless and until such item is added to the written Standards. If any item does not already exist within the Community and is not contained in the written Standards, then such item may not be used or placed within the Community unless and until such item is approved by the Board of Directors, at which time it may be added to the written Standards.

Approval by the ARC is required for any exterior renovations, changes or additions to the structure of the house including exterior painting, changes in windows, doors, roof tiles, exterior light fixtures, canvas awnings, fences, privacy walls, gates, and any other exterior changes. In addition, it applies to the removal of trees, planting of new trees, alterations in existing shrubbery, hedges, flowerbeds or grass plots.

Normal home maintenance and routine repairs do not require ARC approval, provided that products employed are as specified in this document.



The figure above shows the required architectural features for Villa Floresta residences.

Exterior Paint

Villa Floresta Approved Exterior Paint Colors One Gallon and Five Gallon Formulas

SHERWIN-WILLIAMS 702426 06/17/20
239-643-6686 Order# 0237634

EXTERIOR ARCHITECTURAL
SUPER PAINT LATEX
SATIN FM 8000DE

BODY
CUSTOM MANUAL MATCH

CCE*COLORANT	OZ	32	64	128
B1-Black	-	8	-	-
R2-Maroon	-	2	-	1
Y3-Deep Gold	-	29	-	1

ONE GALLON
A89WD1151

EXTRA WHITE
640413761

NOT RECOMMENDED FOR USE ON VINYL

Non Returnable Tinted Color

CAUTION: To assure consistent color, always order enough paint to complete the job and intermix all containers of the same color before application. Mixed colors may vary slightly from color strip or color chip.



0237634-001

Body

SHERWIN-WILLIAMS 702426 06/17/20
239-643-6686 Order# 0237634

EXTERIOR ARCHITECTURAL
SUPER PAINT LATEX
SATIN FM 8000DE

BODY
CUSTOM MANUAL MATCH

CCE*COLORANT	OZ	32	64	128
B1-Black	-	40	-	-
R2-Maroon	-	11	-	1
Y3-Deep Gold	4	18	-	1

FIVE GALLON
A89WD1151

EXTRA WHITE
640413779

NOT RECOMMENDED FOR USE ON VINYL

Non Returnable Tinted Color

CAUTION: To assure consistent color, always order enough paint to complete the job and intermix all containers of the same color before application. Mixed colors may vary slightly from color strip or color chip.



0237634-001

Body

SHERWIN-WILLIAMS 702426 06/17/20
239-643-6686 Order# 0237634

EXTERIOR ARCHITECTURAL
SUPER PAINT LATEX
SATIN FM 8000DE

COMP(FBP) 5770 SHELL WHITE
CUSTOM SHER-COLOR MATCH

CCE*COLORANT	OZ	32	64	128
R3-Magenta	-	-	1	1
Y3-Deep Gold	-	3	-	1

ONE GALLON
A89WD1151

EXTRA WHITE
640413761

NOT RECOMMENDED FOR USE ON VINYL

Non Returnable Tinted Color

CAUTION: To assure consistent color, always order enough paint to complete the job and intermix all containers of the same color before application. Mixed colors may vary slightly from color strip or color chip.



0237634-001

Trim

June 2020



Be sure your painter is aware that the “yellow highlighted” wall shown above is your wall to maintain and paint from front pillar to rear pillar.

Approved paint color formulas shown above the photo are also available at the WHOA office.

Stamped Concrete Driveway & Walkways Paint

TUF-TOP - 12-185 BISON

This Xylene solvent paint may need to be special ordered. It is available in one or five gallon cans and is generally shipped in two to three business days. Local sources:

Sherwin-Williams, Flexbon and Porter Paints

The original Villa Floresta contractors treated our driveways with a Xylene-based coating specially formulated for raw pressed concrete surfaces. A coat of fresh paint with a Xylene solvent partially dissolves the underlying Xylene-based surface and fuses with it. This results in a very tight bond and a lasting paint job.



IMPORTANT: Do not mix Xylene and water-based paint. Unfortunately, over time and with changes in ownership and contractors, some driveways were repainted with water-based paint which is incompatible with Xylene-based surfaces. These are prone to early failure with flaking and peeling. Some Villa Floresta driveways had to be chemically stripped or even sand-blasted to return them to a workable concrete surface

IMPORTANT: Use a Non-Skid Additive: With any Xylene-Based paint, specify a non-skid additive. Use “SharkGrip,” “Slip-Guard,” “Sharkskin” or an equivalent product. Untreated Xylene paint surfaces can be very slippery.

Replacement of Stamped Concrete Driveways with Pavers

Tremron, Inc.
Brick pavers

Size: 4x8 inches
Colors: Body pavers: Coffee Grey-Blend
Border pavers: Taupe Grey-Solid



Aluminum Front & Side-Yard Gates

The arched front courtyard gates (see photo at right) and simpler side yard gates are a custom design.

Approved paint color: gloss white.

Instead of painting, powder coating is an option to restore the finish of the gates. The gates are removed, stripped and the finish is baked-on to last for many years.



Rear Exterior Aluminum Fences

The white aluminum fences along the rear of Villa Floresta properties are a required architectural feature of the neighborhood.

Approved paint color: gloss white

Approved fence replacement: See attached spec sheet from manufacturer

**Manufacturer: Ideal Aluminum
Maine Fence and Gate residential series #203 (with features below)**

Description: Six foot panels, four feet high, 3 channel design, welded circles added between upper two channels. Factory painted gloss white. No finials (Flat post and picket caps). Posts to be set in concrete, including one at each end of the fence run (Fence should not be attached to existing masonry pillars). Include a five foot wide, single swing gate, no arch, with latch and self-closing hinges.



Replacement Fence Contractor:

Gatekeepers 1301 Railhead Blvd., Naples 34110 Tel 239-254-0077

Concrete Tile Roofs

**Manufacturer: Boral Roofing
200 Mansell Court East, Suite #310
Roswell Georgia 30076**

**Product: Barcelona 900 Concrete Roof Tiles
New Southern Blend – 1 HBCS 0100**



Canvas Awnings

Color: bright white (equivalent to Pantone 11-0601)
The rugged aluminum frames can be reused for replacement canvas.

Replacement Awning Cover Contractors:

Naples Awning, Inc. 6563 Taylor Road, Naples, 34105 239-597-9100

Sun Master, Inc. 900 Industrial Blvd., Naples, 34105 239-261-3581



Replacement Mailboxes

Lykins Signtech Incorporated
5935 Taylor Road, Naples, FL 34105 239-594-8494

Replacements for the red, plastic “mail-ready flag” are available at Home Depot or Lykins Signtech



Garage Doors & Garage Side Doors

Clopay 501 woodgrain raised panel steel door

Solid door (no windows) or door with windows and optional inserts

Approved window designs: Sunset 501 – 4 arches
Sunset 503 – 2 arches
Sunset 505 – 1 arch (16 foot door)

Color: white or trim paint color (see page 2)

Replacement window inserts are available from:

Action Automatic Door & Gate, Co. 239-643-3667
#275 Airport-Pulling Road, Naples, Florida 34105



Window inserts for Clopay doors are only available as a full set of 8 inserts. **Color:** white.

Note: doors manufactured by other than Clopay have slightly different inserts

Front Entry Doors

Front doors are to be painted either white or trim paint color (see page 2).

The addition of a screen door, fixed or roll-aside design, requires ARC approval.

Screen Pool Enclosures

Pool cage color: white. ARC approval is required for replacement of a pool cage.

Storm Shutters

Approved Colors: white, beige, brown, black

Exterior Globe Lamps

Approved color for fixture: matte black or original verdigris

1. Original Villa Floresta wall fixture

Replacement Globe: 12 Inch Frosted Acrylic Globe (**neckless**) with 5¼ inch throat opening



2. Alternative fixture

Replacement Globe: 12 inch frosted acrylic globe with 4 inch raised neck opening



3. Approved replacement fixture

Acclaim Lighting - Model# 5261BK/WH Matte Black
White Glass Havana Light Outdoor Wall Sconce

Replacement Globe: 10 inch frosted globe with twist-lock base and 3.75 inch neck opening



4. Replacement Hanging Front Entry Globe: 14 Inch frosted acrylic globe, 5¼ inch neckless throat opening.

Note: Replacement globes are available on the internet

**IMPORTANT: Use Correct Color Temperature Bulbs for All Exterior Lamps
Warm White with color rating of 2,700K**

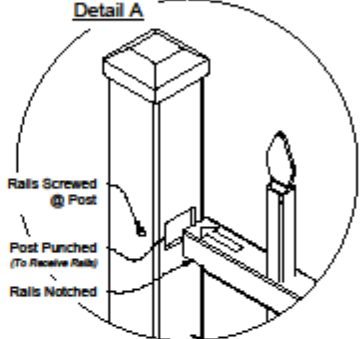
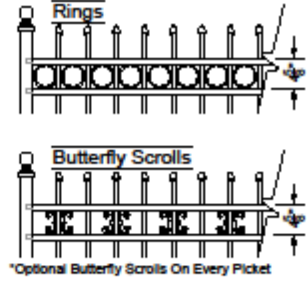
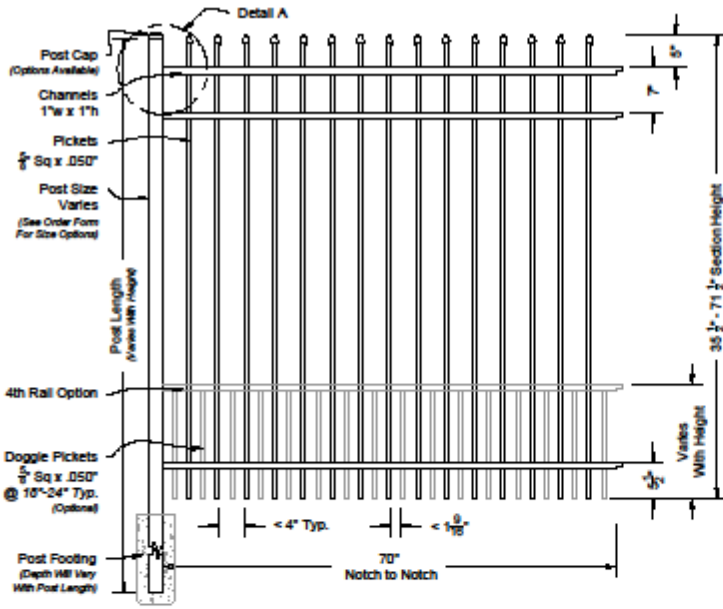

i 01 **Maine #203 6ft Fence Panel**
Shown As Residential Series Scale: NTS

Matching Gate Options

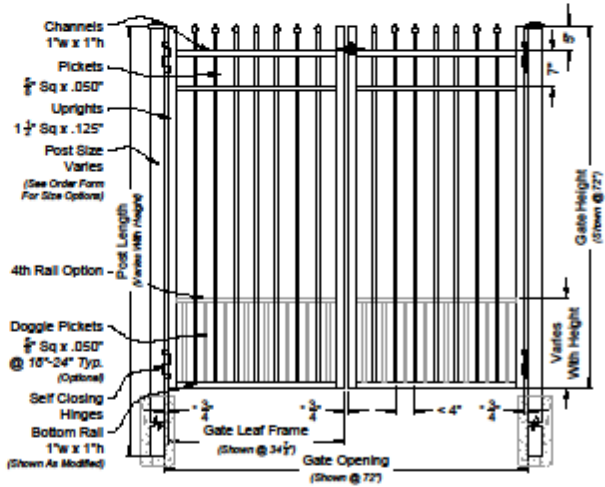
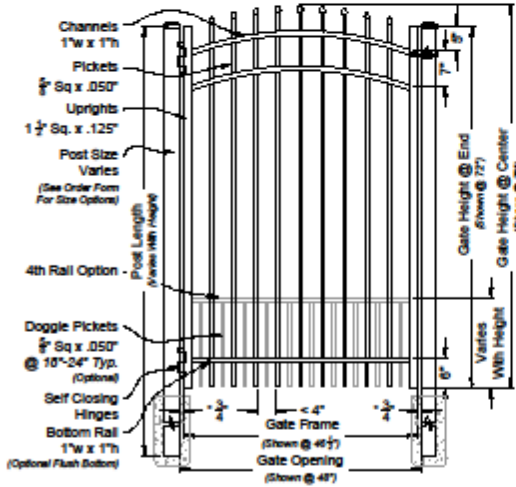

i 02 **Maine Single Walk Gate**
#2033 Arched Rail Option Scale: NTS

i 03 **Maine Double Walk Gate**
#6203M Straight Rail Option Scale: NTS

Maine Fence & Gate
Residential Series #203



DRAWING NOTES:
Don't Scale From Drawings.
Please See Our Fence & Gate Style Sheet For Other Options.
*Other Optional Gate Hardware Available, But May Change The Hinge And Latch Clearances.

Res 203 Series
Fence & Gate
Details

Approved By: iDeal Aluminum Quote #:
Drawn By: JMixon Drawn Date: 26-Nov-13

2000 Brunswick Lane Phone: 386.736.1700
Deland, FL 32724 Fax: 386.822.4956