

**These Standards shall supersede all previous Design and Development Standards whether recorded among the Land Records of Collier County or not.**

## **VILLA FLORESTA DESIGN AND DEVELOPMENT STANDARDS**

Villa Floresta Homeowners Association, Inc. - 98 Wyndemere Way, Naples, Florida 34105

**Approved: August 22, 2024**

Villa Floresta Architectural Review Committee (ARC) Preliminary Approval **July 15, 2024**

Villa Floresta Board of Directors **July 18, 2024**

Wyndemere Homeowners Association ARC **July 23, 2024**

**Adopted by the Villa Floresta ARC Final Approval August 22, 2024**

### **Table of Contents**

INTRODUCTION	2
UNIFORM BUILDING SCHEME	2
EXTERIOR PAINT	3
STAMPED CONCRETE DRIVEWAY & WALKWAYS PAINT	4
REPLACEMENT OF STAMPED CONCRETE DRIVEWAYS WITH PAVERS	4
ALUMINUM FRONT & SIDE-YARD GATES	4
REAR EXTERIOR ALUMINUM FENCES	5
CONCRETE TILE ROOFS	5
CANVAS AWNINGS	5
REPLACEMENT MAILBOXES	5
GARAGE DOORS	6
SCREEN POOL ENCLOSURES	6
HURRICANE PROTECTION	6
GENERATORS AND FUEL STORAGE TANKS	6
EXTERIOR WALL LIGHTS	7
EXTERIOR FRONT ENTRY LIGHT	8
ADDITIONAL REQUIREMENTS:	9
Flags	9
Exterior Lighting	9
APPROVED REPLACEMENT FENCE	10

## **INTRODUCTION**

The “Declaration of Covenants, Restrictions and Easements for Villa Floresta” (“Declaration”), Section 10, provides for “Architectural and Aesthetic Control.” Under that section, an Architectural Review Committee (ARC), appointed by the Board of Directors, is empowered to publish or modify design and development standards (“Standards”).

The purpose of this document is to provide the “Standards” for Villa Floresta as required in the “Declaration”, Section 10, which states: “No construction, which term shall include within its definition, but not limited to, staking, clearing, excavation, grading and other site work; no exterior alteration or modification of existing improvements; or removal of trees or shrubs shall take place anywhere on the Community ... until the approval of the ARC has been obtained.” In addition, the Wyndemere Homeowners Association (“Master Association”) Declaration, Article VI, “Restrictions on Occupancy and Use of Land” requires approval by the Master Association ARC. The appropriate ARC Change Form to initiate all projects is available at the Wyndemere Homeowners Association office.

**Approval by the ARC is required** for any exterior renovations, changes or additions to the structure of the house including *exterior painting, changes in windows, doors, roof tiles, exterior light fixtures, canvas awnings, fences, privacy walls, gates, and any other exterior changes.* In addition, it applies to the removal of trees, planting of new trees, alterations in existing shrubbery, hedges, flowerbeds or grass plots.

## **UNIFORM BUILDING SCHEME**



**All improvements in Villa Floresta should conform to a *Uniform Building Scheme*.** The figure above shows the required architectural features for Villa Floresta residences.

# EXTERIOR PAINT

## Option 1 (Original Paint Colors)

### Villa Floresta Approved Exterior Paint Colors One Gallon and Five Gallon Formulas

SHERWIN-WILLIAMS 702426 239-643-6686	06/17/20 Order# 0237634	ARCHITECTURAL LATEX FM 8000DE
EXTERIOR SUPER PAINT SATIN		
BODY CUSTOM MANUAL MATCH		
CCE#COLORANT	OZ	32 64 128
B1-Black	-	8 - -
R2-Maroon	-	2 - 1
Y3-Deep Gold	-	29 - 1

SHERWIN-WILLIAMS 702426 239-643-6686	06/17/20 Order# 0237634	ARCHITECTURAL LATEX FM 8000DE
EXTERIOR SUPER PAINT SATIN		
BODY CUSTOM MANUAL MATCH		
CCE#COLORANT	OZ	32 64 128
B1-Black	-	40 - -
R2-Maroon	-	11 - 1
Y3-Deep Gold	4	18 - 1

SHERWIN-WILLIAMS 702426 239-643-6686	06/17/20 Order# 0237634	ARCHITECTURAL LATEX FM 8000DE
EXTERIOR SUPER PAINT SATIN		
COMP(FBP) 5770 SHELL WHITE CUSTOM SHER-COLOR MATCH		
CCE#COLORANT	OZ	32 64 128
R3-Magenta	-	- 1 1
Y3-Deep Gold	-	3 - 1

ONE GALLON  
A89WD1151

EXTRA WHITE  
640413761

NOT RECOMMENDED FOR USE ON VINYL

Non Returnable Tinted Color  
CAUTION: To assure consistent color, always order enough paint to complete the job and intermix all containers of the same color before application. Mixed colors may vary slightly from color strip or color chip.



0237634-001

Body

FIVE GALLON  
A89WD1151

EXTRA WHITE  
640413779

NOT RECOMMENDED FOR USE ON VINYL

Non Returnable Tinted Color  
CAUTION: To assure consistent color, always order enough paint to complete the job and intermix all containers of the same color before application. Mixed colors may vary slightly from color strip or color chip.



0237634-001

Body

ONE GALLON  
A89WD1151

EXTRA WHITE  
640413761

NOT RECOMMENDED FOR USE ON VINYL

Non Returnable Tinted Color  
CAUTION: To assure consistent color, always order enough paint to complete the job and intermix all containers of the same color before application. Mixed colors may vary slightly from color strip or color chip.



0237634-001

Trim

June 2020

## Option 2

**Body-** Sherwin Williams SW9180 Aged White Satin Finish

**Trim-** Sherwin Williams SW7006 Extra White

Any pipes or other appurtenances adhered to the house or walls, must be painted the color of the house body or trim so they match. Be sure to check with utility companies first to ensure that their boxes may be painted.



Be sure your painter is aware that the "yellow highlighted" wall shown above is your wall to maintain and paint from front pillar to rear pillar.

## STAMPED CONCRETE DRIVEWAY & WALKWAYS PAINT

### **TUF-TOP - 12-185 BISON**

This Xylene solvent paint may need to be special ordered. It is available in one or five gallon cans and is generally shipped in two to three business days. Local sources:

#### **Sherwin-Williams, Flexbon and Porter Paints**

The original Villa Floresta contractors treated our driveways with a Xylene-based coating specially formulated for raw pressed concrete surfaces. A coat of fresh paint with a Xylene solvent partially dissolves the underlying Xylene-based surface and fuses with it. This results in a very tight bond and a lasting paint job.

**IMPORTANT: Do not mix Xylene and water-based paint.** Unfortunately, over time and with changes in ownership and contractors, some driveways were repainted with water-based paint which is incompatible with Xylene-based surfaces. These are prone to early failure with flaking and peeling. Some Villa Floresta driveways had to be chemically stripped or even sand-blasted to return them to a workable concrete surface

**IMPORTANT: Use a Non-Skid Additive:** With any Xylene-Based paint, specify a non-skid additive. Use "SharkGrip," "Slip-Guard," "Sharkskin" or an equivalent product. Untreated Xylene paint surfaces can be very slippery.



---

## REPLACEMENT OF STAMPED CONCRETE DRIVEWAYS WITH PAVERS

Tremron, Inc.  
Brick pavers

Size: 4x8 inches  
Color: Beach Side

---

## ALUMINUM FRONT & SIDE-YARD GATES

The arched front courtyard gates (see photo at right) are a custom design. Side and rear yard gates match the fences. See photos below.



**Approved paint color: gloss white.**

Instead of painting, powder coating is an option to restore the finish of the gates. The gates are removed, stripped and the finish is baked-on to last for many years.

## **REAR EXTERIOR ALUMINUM FENCES**

The white aluminum fences along the rear of Villa Floresta properties are a required architectural feature of the neighborhood.

**Approved paint color: gloss white**

**Approved fence replacement: See attached spec sheet from manufacturer**

**Manufacturer: Ideal Aluminum  
Maine Fence and Gate residential series #203 (with features below)**

**Description:** Six foot panels, four feet high, 3 channel design, welded circles added between upper two channels. Factory painted gloss white. No finials (Flat post and picket caps). Posts to be set in concrete, including one at each end of the fence run (Fence should not be attached to existing masonry pillars). Include a five foot wide, single swing gate, no arch, with latch and self-closing hinges. **Only one (1) rear gate location is permitted.**



**Replacement Fence Contractor:**  
**Gatekeepers** 1301 Railhead Blvd., Naples 34110 Tel 239-254-0077

---

## **CONCRETE TILE ROOFS**

**Manufacturer: Boral Roofing  
200 Mansell Court East, Suite #310  
Roswell Georgia 30076**

**Product: Barcelona 900 Concrete Roof Tiles  
New Southern Blend – 1 HBCS 0100**



---

## **CANVAS AWNINGS**

**Color:** bright white (equivalent to Pantone 11-0601)  
The rugged aluminum frames can be reused for replacement canvas.

**Replacement Awning Cover Contractors:**

**Naples Awning, Inc.** 6563 Taylor Road, Naples, 34105 239-597-9100  
**Sun Master, Inc.** 900 Industrial Blvd., Naples, 34105 239-261-3581



---

## **REPLACEMENT MAILBOXES**

**Lykins Signtech Incorporated**  
5935 Taylor Road, Naples, FL 34105 239-594-8494

Replacements for the red, plastic "mail-ready flag" are available at Home Depot or Lykins Signtech

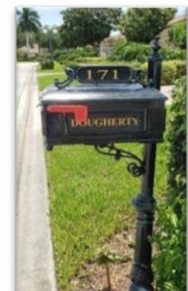

## **GARAGE DOORS**

Clopay 501 woodgrain raised 8 panel steel door (or similar design from other manufacturer)

Solid door (no windows) or door with windows (inserts are optional)

Approved window insert designs:     Sunset 501 – 4 arches  
   Sunset 503 – 2 arches  
   Sunset 505 – 1 arch (16 foot door)

Color: white, trim paint color, or house body color (see page 2)

Replacement window inserts are available from:

**Action Automatic Door & Gate, Co.** 239-643-3667  
#275 Airport-Pulling Road, Naples, Florida 34105



Window inserts for Clopay doors are only available as a full set of 8 inserts. **Color:** white.

**Note:** doors manufactured by other than Clopay have slightly different inserts

---

## **FRONT ENTRY DOORS**

Front doors are to be painted either white or trim paint color (see page 2).

The addition of a screen door, fixed or roll-aside design, requires ARC approval.

---

## **SCREEN POOL ENCLOSURES**

Pool cage color: white.     ARC approval is required for replacement of a pool cage.

---

## **HURRICANE PROTECTION**

Storm Shutters     ARC approval is required for installation of all storm shutters

Metal roll down shutters     color: white or house body color

Polypropylene roll down fabric screens     color: white, beige, brown, black, clear polycarbonate

Polycarbonate (Lexan) clear panels (non-permanent)

Villa Floresta allows all homeowners to lower their approved storm shutters while they are away from their home for a temporary or extended period of time as well as in the event of an approaching storm that may be dangerous to their home while they are in residence. Roll down screens may be lowered for shade and/or privacy at any time.

## **GENERATORS AND FUEL STORAGE TANKS**

Exterior fixed generators and fuel storage tanks must not be visible from the street or the golf course. Masking with shrubbery is required if they are visible.

---

## EXTERIOR WALL LIGHTS

1. Original Villa Floresta wall fixtures are no longer available but the globes can be obtained on the internet)

**Approved color for fixture:** matte black or original verdigris



**Replacement Globe:** 12 Inch Frosted Acrylic Globe (**neckless**) with 5¼ inch throat opening

**Replacement Globe:** 12 inch frosted acrylic globe with 4 inch raised neck opening



2. Replacement wall fixtures

- a. **Acclaim Lighting** - Model# 5261BK/WH Matte Black White Glass Havana Light Outdoor Wall Sconce

**Replacement Globe:** 10 inch frosted globe with twist-lock base and 3.75 inch neck opening



- b. **Quoizel WVR8409EK**

Clear Beveled Glass, Incandescent 2 Candelabra Base, 60 watt bulbs  
Earth Black Steel

Available online or

Naples Lighting and Fan Depot  
4572 Tamiami Trail N, Naples, FL 34103  
(239) 261-7585



- c. **Kichler Regence outdoor wall light 59126BK**

Clear glass, 2 bulbs E12 Candelabra style incandescent bulbs.  
Textured black.

**EXTERIOR FRONT ENTRY LIGHT** (original hanging globe or one of the choices shown below)

**Original Hanging Front Entry Globe Replacement:** 14 Inch frosted acrylic globe, 5 1/4 inch neckless throat opening.  
**Note:** Replacement globes are available on the internet



**1. Quoizel WVR1907EK Westover Outdoor Lantern**

Earth Black Steel  
Clear Beveled Glass Incandescent bulb 1- 150 watt medium base  
Chain/Downrod Length 8'

**Note:** when installing, the chain length should not allow the light to swing into the half-moon window above the front door.

Available online or

Naples Lighting and Fan Depot  
4572 Tamiami Trail N, Naples, FL 34103  
(239) 261-7585



**2. Kichler Regence 2-Light outdoor Pendant 59130BKT**

Clear glass, 2 bulbs E12 Candelabra style incandescent bulbs.  
Textured black.

**Note:** when installing, the chain length should not allow the light to swing into the half-moon window above the front door.

**3. Recessed light fixture in lieu of hanging fixture**

**All exterior front and side lights must match.**

**IMPORTANT: Use Correct Color Temperature Bulbs for All Exterior Lamps Warm White with color rating of 2,700K**

---



## **ADDITIONAL REQUIREMENTS:**

1. Accessory air conditioning units, exterior fixed generators and propane tanks may not be visible from the street or the golf course. Masking with shrubbery is required if they are visible.
2. The following are **not** permitted in Villa Floresta:
  - a. Above ground swimming pools
  - b. Dog runs
  - c. Fixed basketball hoops. Portable basketball hoops must be stored in the garage when not in use.
  - d. Playground equipment
  - e. Pool slides and diving boards
3. The following are permitted with limits as noted:

**Flags:** Flags may be flown in compliance with Florida Statute 720.304. No other flags shall be permitted except holiday flags, garden flags, and sports team flags. Flags may be flown attached to the garage.

**Exterior Lighting:** No spotlights, floodlights or similar high intensity lighting will be placed or utilized upon any lot which in any way will allow light to be reflected on any other lot or upon any common area without the approval of the ARC. Other types of low intensity lighting, including normal and customary Christmas or other holiday decorations, which do not unreasonably disturb other owners or occupants of the Community, will be allowed. Holiday lighting may be displayed 30 days before the holiday and must be removed 15 days after the holiday.

# APPROVED REPLACEMENT FENCE

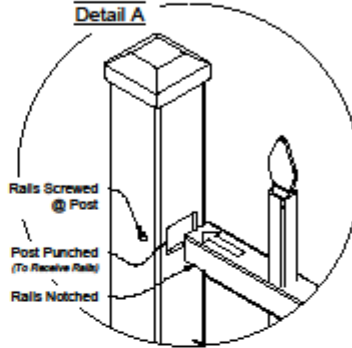
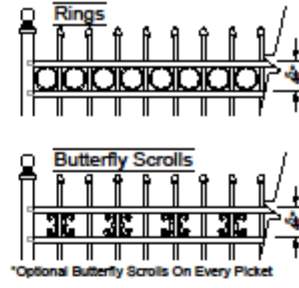
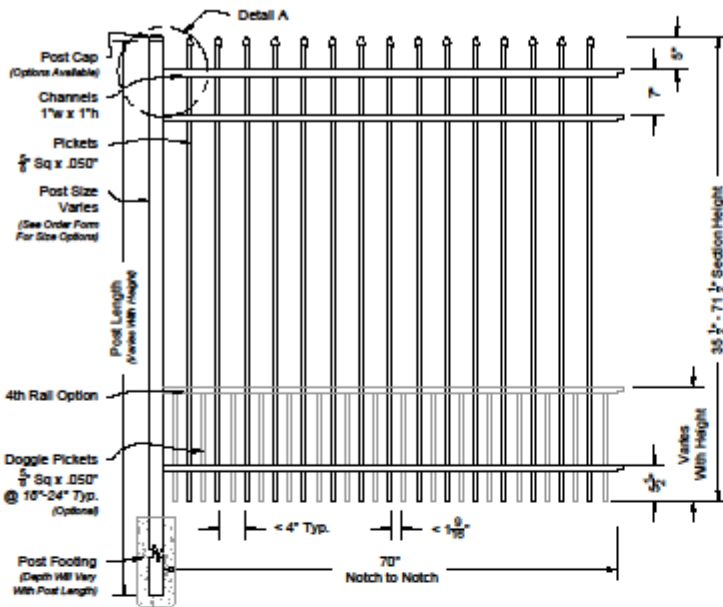

**01** Maine #203 6ft Fence Panel  
Shown As Residential Series Scale: NTS

## Matching Gate Options

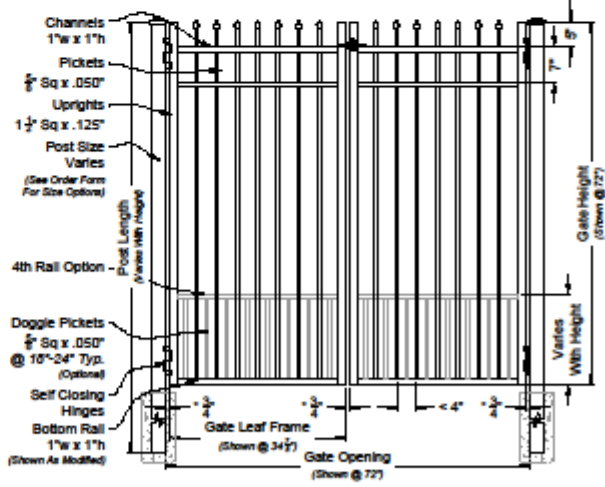
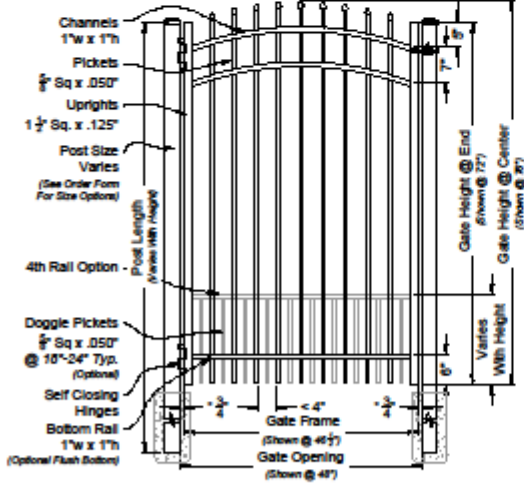

**02** Maine Single Walk Gate  
#2033 Arched Rail Option Scale: NTS

**03** Maine Double Walk Gate  
#6203M Straight Rail Option Scale: NTS

Maine Fence & Gate  
Residential Series #203



**DRAWING NOTES:**  
Don't Scale From Drawings.  
Please See Our Fence & Gate Style Sheet For Other Options.  
\*Other Optional Gate Hardware Available, But May Change The Hinge And Latch Clearances.

Res 203 Series  
Fence & Gate  
Details

Approved By: iDeal Aluminum Quote #:  
Drawn By: JMixon Drawn Date: 26-Nov-13

2000 Brunswick Lane Phone: 386.736.1700  
Deland, FL 32724 Fax: 386.822.4956

1 OF 1